



TECHICAL SPECIFICATION FOR
LITHIUM MANGANESE DIOXIDE BATTERY

CR-2016

FILE NO: DSE-CR-CR2016-V15A

EDITION : V15A

DATE : 2015/09/25

Prepared By	Checked By	Approved By
QE1	QE	A

1. SCOPE

This specification shall be applied to MOTOMA industrial lithium manganese dioxide battery of CR2032. The all technical data and materials list are for the industrial purpose only

BATTERY MODEL:

CR-2016-75mAh

APPLICATION:

Electronic dictionary, Remote control, Toys, Horologe, Electronic scales, Electronic perpetual calendar, Electronic flash products etc.

2. CHARACTERISTICS

2.1 Nominal voltage

3V

2.2 Normal capacity: 210mAh (continuous discharge at 20°C under 15KΩ load to 2.0V cut-off voltage)

2.3 Open-circuit voltage: ≥3.20V

2.4 Instantaneous short-circuit current: ≥250mA

2.5 Discharge cut-off voltage: 2.0V (20°C)

● **2.6 Operate temperature range:** -20~+60°C

2.7 Storage temperature range: 0~+35°C

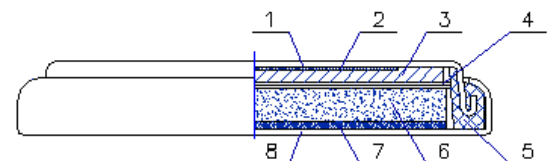
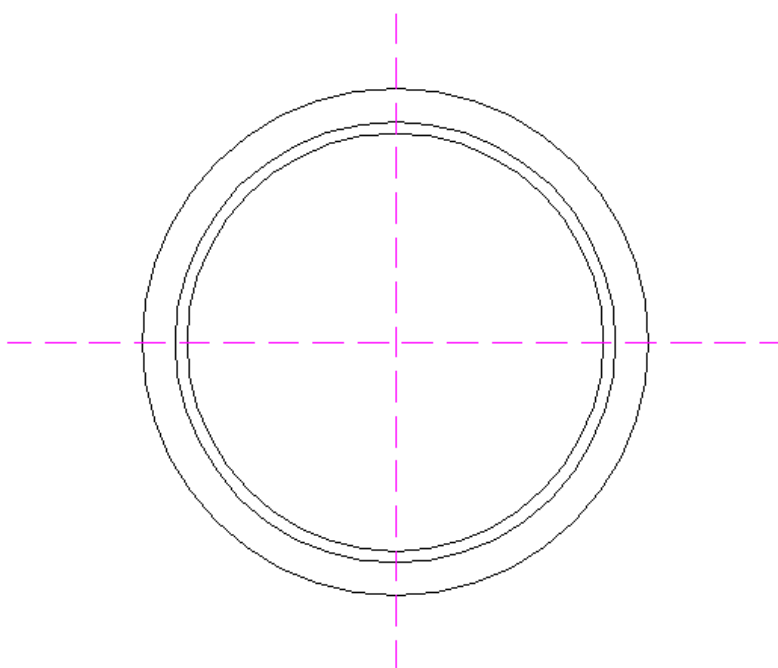

1. Anode cup, 2. Anode collector net, 3. Anode (Lithium metal), 4. Separator, 5. Gasket, 6. Cathode (MnO₂), 7. Cathode collector net, 8. Cathode can, Cutaway View of Lithium Manganese Dioxide (Coin type)

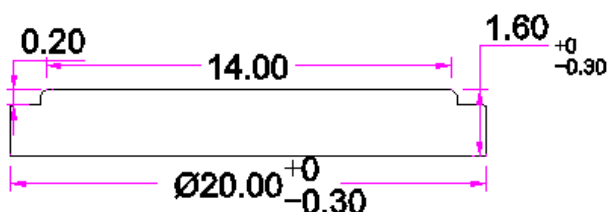

4. APPEARANCE PERFORMANCE

4.1 TEST REQUIREMENTS

Testing Conditions (unless otherwise specified):

- Temperature: +15~+25°C
- Relative Humidity: 45%~85%

4.2 TEST METHOD AND PERFORMANCE

4.2.1 APPEARANCE

No deformation, dent, stain, leakage and camber which influence the value of the battery.

4.2.2 CAPACITY

After keeping the battery for 8hrs at 20°C, continuous discharge at 20±5°C and relative humidity at 65±20% under 15KΩ load to 2.0V cut-off voltage.

4.2.3 OPEN-CIRCUIT VOLTAGE

Using multimeter (accuracy≥0.25%) internal resistance≥1MΩ

4.2.4 SHORT-CIRCUIT CURRENT (INSTANTANEOUS)

The time of short-circuit should be less than 0.5 second and avoid repeated test within half an hour

4.2.5 SELF-DISCHARGE

The battery continuously discharged with 15KΩ load till 2.0V end-voltage after the storage at room temperature of 12 months. The capacity shall be ≥60 mAh

4.2.6 OVER DISCHARGE

The battery shall not cause leakage when it is continuously discharged for 5 hours after it discharged with 7.5KΩ load to 2.0V end-voltage.

4.2.7 STORAGE

The battery stored under high temperature (45°C) for 30 days, the Leakage rate shall be less than 1%.

4.2.8 VIBRATION

The performance of battery shall keep stability when tested with the frequency form 10 to 15 times per minute. Keeps it running for an hour.

5. SUGGESTION & ADVICE

5.1 Install batteries correctly.

5.2 Ensure the contact points to be clean and conductive.

5.3 Do not mix different types, different brands batteries to serve together.

5.4 Do not heat, recharge the batteries.

5.5 Do not dispose of the batteries in fire.

5.6 Keep away from the small children, if swallowed promptly see doctor.

5.7 Pay attention to the producing date.

5.8 Avoiding soldering directly to the battery.

Manufacturer reserves the right to alter or amend the design, model and specification without prior notice.

Discharge Characteristics Curve

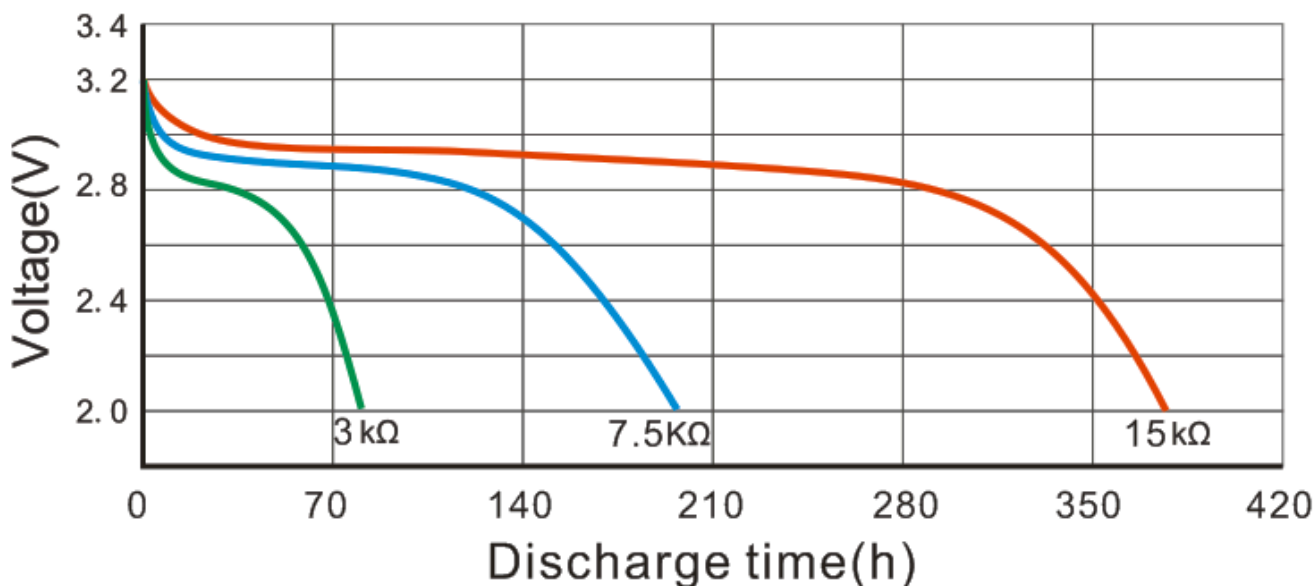

Discharge Characteristics Curve

